

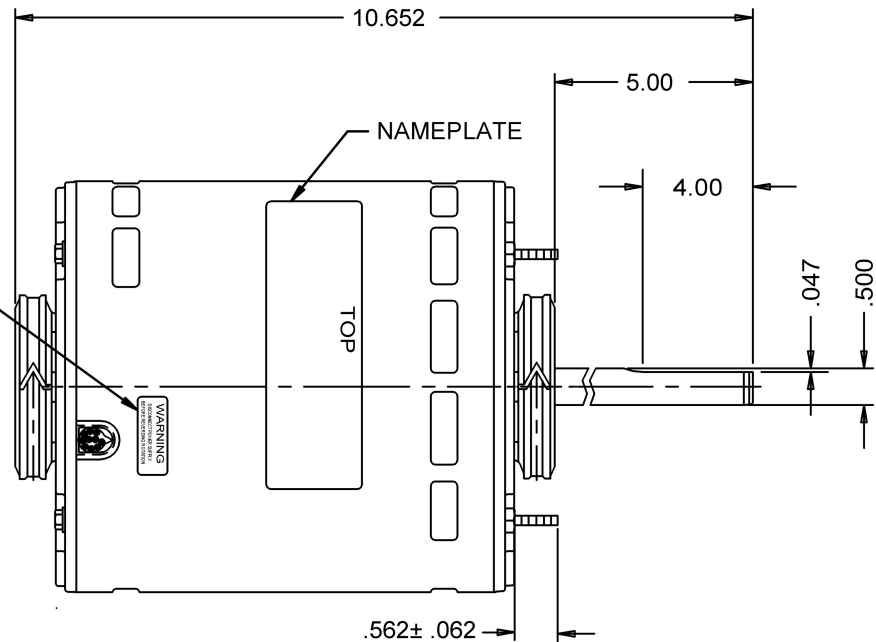

## Catalog #: 1972

Model_Number:	K055WML1257012B
PRODUCT NAME:	.33 HP - OAO - 1075
PHASETYPE:	1_PERMANENT SPLIT CA
MOTOR ENCLOSURE:	OAO
HORSEPOWER:	.33
KILOWATTS:	0.3
POLES:	6
NUMBER SPEEDS:	3
RPM:	1075
HERTZ:	60
VOLTS PRIMARY:	208-230 V
VOLTS :	208
VOLTS 2:	230
FRME :	48
SHAFT CODE:	Y
STATOR DIAMETER:	5.5
STACK:	1.5
MOUNTING:	BAND/HUB/STUD
MOTOR TYPE:	FHP
OPPOSITE END BEARING:	SELF-ALIGN
SHAFT END BEARING:	SELF-ALIGN
AMBIENT:	40
ROTATION:	CCW LEAD END REV
SERVICE FACTOR:	1
RUNCAPMFD:	7.5
RUNCAPVOLTS:	370
SHIPPING WEIGHT:	12
THERMAL PROTECTION:	AUTOMATIC RESET
BREAKDOWN TORQUE:	38.7
BREAKDOWN TORQUE UOM:	OZFT
LOCKED ROTOR TORQUE:	12.48
LOCKED ROTOR TORQUE UOM:	OZFT
INSULATION CLASS:	B
LOCKED ROTOR AMPS:	4.09
FULL LOAD AMPS PRIMARY:	1.9

#16 GREEN GROUND LEAD TO BE 12.00 BETWEEN CENTERS OF TERMS. TERM. TO FIT #10 SCREW.

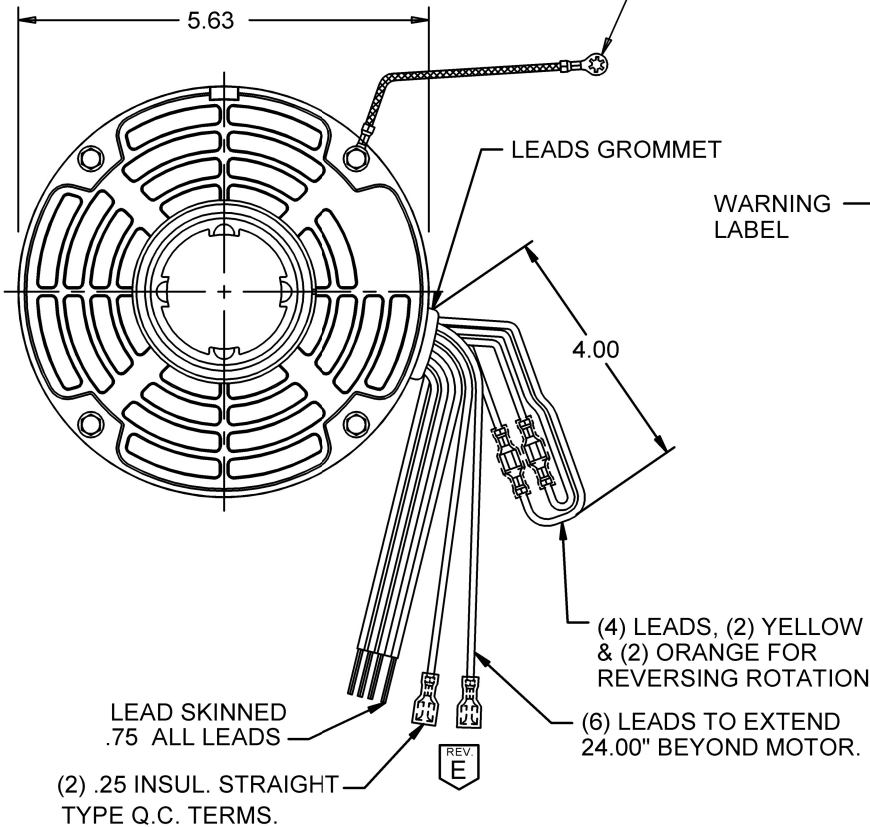

CONNECTION SHOWN IS FOR C.W. LE. ROTATION TO REVERSE ROTATION, INTERCHANGE ORANGE AND YELLOW LEADS.

COLOR CODE  
 WHITE-COMMON  
 BLACK-HIGH  
 BLUE-MEDIUM  
 RED-LOW  
 BROWN-CAPACITOR

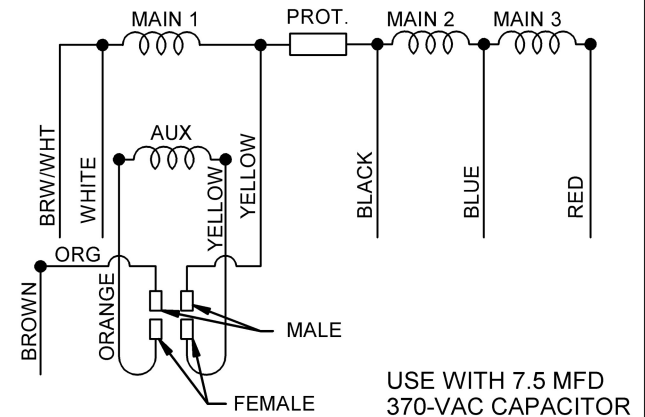

USE WITH 7.5 MFD 370-VAC CAPACITOR

NIDEC MOTOR CORPORATION 28-May-13

MODEL	REF	CUSTOMER	HP	VOLTS	AMPS	HZ	RPM	ROTATION	CUSTOMER PN
K55HXWML-1257	A30151-X3	WHOLESALE-HAC	1/3	208-230	1.9	60	1075/ 3 SPD	CCW LEAD END REV	1972

SHEET NUMBER	REV	REVISION RECORD FOR:	ITEM NO.
1 OF 1	E	STRAIGHT TERMINALS ON BRN LEADS WAS WITHOUT INSULATION.	C7693-00
REVISION DATE			
29-MAY-13			
ISSUED BY	REVIEWED BY	ENGINEER APPROVED	
R. GUZMAN	M. LARGENT	B. GAITAN	

INFORMATION DISCLOSED ON THIS DOCUMENT IS CONSIDERED PROPRIETARY AND SHALL NOT BE REPRODUCED OR DISCLOSED WITHOUT WRITTEN CONSENT OF NIDEC MOTOR CORPORATION
ALL DIMENSIONS ARE FOR REFERENCE ONLY UNLESS TOLERANCE IS GIVEN
TITLE
ASSEMBLED VIEW

<b>NIDEC MOTOR CORPORATION</b>		
CODE	ITEM NO.	SIZE
V01	781055	A

## Permanent Split Capacitor Direct Drive Fan & Blower 5.6" Diameter, Open Air Over

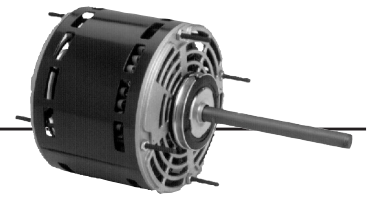

### APPLICATIONS:

Residential and commercial direct drive fans and blowers.

### FEATURES:

- Stud Extensions On Popular Models
- Designed for use with 370V Capacitors
- Class B Insulation
- 24" Leads
- Continuous Duty, Air Over
- Bearings Have All Angle Thrust System
- Reversible Rotation
- For Flex Mount, Order Catalog # 44; See Page 182
- Automatic Reset Thermal Overload Protector
- Connection and Capacitor Information Furnished in the Nameplate Data
- 2.5" Dia. Hub Rings Included
- All Angle Mount
- **Discount Symbol: DS-3HAC**

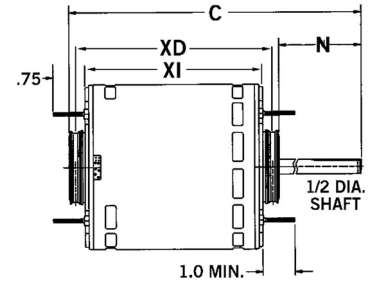

### Hub Ring Mount (2.5") except as noted, Without Capacitor

HP	RPM/ Spds.	Voltage	Catalog Number	List	Cap. MFD	Amps	Shaft N	Base XD	Shell XI	Total C	Ship Wt.	Notes	OEM
1/4	1075/3	115	1863	\$112	7.5	3.5	5.0	5.4	4.9	10.4	10		
	1625/3	115	1690	\$214	10.0	2.7	6.0	4.7	4.1	11.1	11.6		
	1075/3	208-230	1971	\$114	7.5	1.5	5.0	5.4	4.9	10.4	9		
	1075/3	277	600	\$236	4.0	1.6	5.0	5.2	4.6	11.7	13	69	
1/3	1075/3	115	1864	\$115	7.5	5.0	5.0	5.6	5.1	10.7	12		
	1625/3	115	1692	\$220	15.0	3.7	6.0	4.8	4.3	11.4	13		
	1075/3	208-230	1972	\$118	7.5	1.9	5.0	5.6	5.1	10.7	11		
	1075/3	277	601	\$218	4.0	2.2	6.0	5.5	5.0	11.9	14	69	
	1625/3	208-230	1693	\$227	5.0	2.1	4.5	5.1	4.6	10.7	13		
1/3-1/8	825/2	208-230	5469	\$218	7.5	2.4	4.5	-	5.3	9.8	17	72	
1/2	825/3	208-230	8064	\$249	20.0	4.4	2.5	6.6	6.1	9.7	20	69	LE
	1075/3	115	1865	\$139	10.0	6.5	5.0	6.4	5.9	11.4	16		
	1625/3	115	1694	\$235	20.0	5.5	5.0	5.9	5.3	11.4	15.6	A	
	1075/3	208-230	1973	\$144	10.0	2.9	5.0	6.2	5.7	11.7	17		
	1075/3	277	602	\$299	6.0	3.4	6.0	5.7	5.2	12.2	15	69	
	1625/3	208-230	1695	\$240	15	5.0	3.5	-	4.8	8.3	12	H11,LA	RH
1/2-1/6	1075/4	115	5460	\$148	10.0/7.5	7.3	5.5	5.9	5.3	11.3	20	72	
	1075/4	208-230	5461	\$151	10/5	3.6	5.0	5.9	5.3	10.8	15	72	
3/4	1625/3	115	1696	\$250	15.0	8.6	6.0	5.9	5.4	12.4	20		
	1625/3	208-230	1697	\$255	10.0	4.4-4.2	6.0	5.9	5.4	12.4	19	A	
	1075/3	115	8904	\$159	15.0	9.5	5.0	6.4	5.9	11.4	11	69	
	1075/3	208-230	8905	\$160	15.0	4.0	5.0	6.6	6.1	11.6	17	69	
	1075/3	277	5847	\$298	15.0	4.1	6.0	6.7	6.2	13.2	19		
	1075/4	115	3340	\$340	7.5	12.1	6.0	5.8	5.3	12.4	18		CA
	1075/5	208-230	8065	\$606	20	5.0	2.5	8.5	8.0	11.4	18		
	1075/4	115	6452	\$221	15.0	11.2	5.0	-	5.8	10.8	18	69, H11	
	1075/2	208-230	5471	\$181	20/10	4.1	5.0	6.6	6.1	12.1	16	72	
	1075/3	460	LX7930	\$246	20	2.3	2.5	5.8	5.3	8.9	17	69	LE
3/4-1/5	1075/2	115	5470	\$177	20/10	8.1	5.0	6.6	6.1	11.6	17	72	
1	1075/3	115	8906	\$298	20.0	12.1	5.0	6.6	6.1	12.2	22	H17	
	1075/3	208-230	8907	\$301	20.0	5.6	5.0	6.6	6.1	12.2	22	H17	
	1625/3	115	1699	\$265	25.0	11.1	6.0	6.4	5.9	12.9	22	H7	
	1625/3	208-230	1700	\$278	20.0	5.1	6.0	5.9	5.3	12.4	20		

CA = Carrier LE = Lennox RH=Rheem

Note 69: No Stud Extension

Note A: Class A Insulation

Note H7: 36" Leads, 2.25" Dia. Hubs With 2.5" Dia. Kit Included.

Note LA Limited Availability

Note H11: Band Mount

Note H17: Class B Insulation, Studs Shaft Side Only, Ball Bearings

Note 72: Includes 4 Holes In Shell For Rheem Mount